



## Short Report

# *ACVRL1* germinal mosaic with two mutant alleles in hereditary hemorrhagic telangiectasia associated with pulmonary arterial hypertension

Eyries M, Coulet F, Girerd B, Montani D, Humbert M, Lacombe P, Chinet T, Gouya L, Roume J, Axford MM, Pearson CE, Soubrier F. *ACVRL1* germinal mosaic with two mutant alleles in hereditary hemorrhagic telangiectasia associated with pulmonary arterial hypertension. Clin Genet 2011. © John Wiley & Sons A/S, 2011

Germline mutations in genes encoding members of the transforming growth factor- $\beta$  (TGF- $\beta$ )/bone morphogenetic protein (BMP) superfamily are causal for two hereditary vascular disorders, hereditary hemorrhagic telangiectasia (HHT) and heritable pulmonary arterial hypertension (PAH). When the two diseases coexist, activin A receptor type II-like kinase-1 (*ACVRL1*) gene mutations are usually identified. We report a remarkable *ACVRL1* germinal and somatic mosaicism characterized by the presence of two distinct mutant alleles and a non-mutant *ACVRL1* allele in a woman diagnosed with PAH at the age 40. She also met the Curaçao diagnostic criteria for HHT based on additional findings of telangiectases, epistaxis and arteriovenous malformations. Mutation analysis of *ACVRL1* identified two adjacent heterozygous deleterious mutations within exon 10: c.1388del (p.Gly463fsX2) and c.1390del (p.Leu464X) in a region enriched by mutation-associated DNA motifs. The mother transmitted the c.1388del to one child and the c.1390del to two children confirming germinal mosaicism. Allele-specific polymerase chain reaction analysis showed that c.1388del is the predominant mutation in lymphocytes of the index case. Haplotype analysis revealed that both mutant alleles have a common chromosomal origin which is distinct from that of the mother's non-mutant *ACVRL1* allele. These distinct mutant alleles in tissues and germline could have arisen by DNA structure-mediated events occurring in the early stages of the mother's embryogenesis, prior to the segregation of her germline, which ultimately led to the independent transmission of each allele. These highlight the complexity of genomic events occurring during early embryogenesis and the consequences of mutational mosaicism upon pathogenic variability.

### Conflict of interest

All authors declare no conflict of interest.

**M Eyries<sup>a,b,c</sup>, F Coulet<sup>a,b,c</sup>,  
B Girerd<sup>d</sup>, D Montani<sup>d</sup>,  
M Humbert<sup>d</sup>, P Lacombe<sup>e</sup>,  
T Chinet<sup>f</sup>, L Gouya<sup>g</sup>, J Roume<sup>g</sup>,  
MM Axford<sup>h,i</sup>, CE Pearson<sup>h,i</sup>  
and F Soubrier<sup>a,b,c</sup>**

<sup>a</sup>Oncogenetics and Angiogenetics Laboratory, Groupe Hospitalier Pitié-Salpêtrière, Assistance Publique Hôpitaux de Paris, France, <sup>b</sup>UPMC Univ Paris 06, UMR\_S 956, F-75005, Paris, France, <sup>c</sup>INSERM UMR\_S 956, Faculté de médecine Pitié-Salpêtrière, F-75013, Paris, France, <sup>d</sup>National Reference Centre for Severe Pulmonary Hypertension, Department of Pulmonary and Critical Care Medicine, Hôpital Antoine Bécclère, Université Paris-Sud, Assistance Publique Hôpitaux de Paris, Clamart, France, <sup>e</sup>Radiology Department, <sup>f</sup>Pneumology Department, and <sup>g</sup>Genetics Department, MRO Center, Hôpital Ambroise Paré, Paris, France, <sup>h</sup>Genetics & Genome Biology, The Hospital for Sick Children, Toronto, Ontario, Canada, <sup>i</sup>Department of Molecular Genetics, University of Toronto, Toronto, Ontario, Canada

Key words: *ACVRL1*-allele-specific assay – germinal mosaicism – hereditary hemorrhagic telangiectasia – mutation-associated DNA motifs – novel mutations – pulmonary hypertension

Corresponding author: Florent Soubrier, Laboratoire d'Oncogénétique et d'Angiogénétique Moléculaire, Groupe Hospitalier Pitié-Salpêtrière, 47 Boulevard de l'hôpital, 75013 Paris, France.  
Tel.: 0033142177664;  
fax: 0033142177618;  
e-mail: florent.soubrier@psl.aphp.fr

Received 12 April 2011, revised and accepted for publication 3 June 2011

Pulmonary arterial hypertension (PAH) and hereditary hemorrhagic telangiectasia (HHT) are distinct clinical entities caused by germline heterozygous mutations in genes encoding members of the TGF- $\beta$ /BMP superfamily: *BMPR2* in PAH and *ACVRL1*, *ENG*, or *SMAD4* in HHT. HHT is characterized by mucocutaneous telangiectases, recurrent epistaxis, and macroscopic arteriovenous malformations, particularly in the pulmonary, hepatic, and cerebral circulation (1). PAH is a severe disease affecting small pulmonary arteries, with progressive remodeling leading to elevated pulmonary vascular resistance and right ventricular failure (2). Genetic predisposition to PAH has been shown to be linked to mutations of *BMPR2*, which are responsible for heritable forms of PAH, transmitted as an autosomal dominant trait with low penetrance. When PAH complicates HHT, *ACVRL1* mutation are the prevailing cause of the disease (3, 4).

Here, we report a remarkable *ACVRL1* germline and somatic mosaicism characterized by the presence of two mutant alleles in the same patient diagnosed with HHT and PAH, those arose on the same haplotype and were independently transmitted to the offspring.

## Materials and methods

### DNA extraction

Genomic DNA was isolated from peripheral lymphocytes using an automatized Extragene extractor (Genomic Industry, Archamps, France) with a DNA extraction kit Wizard Genomic DNA (Promega, Charbonnières-les-Bains, France) according to the manufacturer's standard protocol. Extraction from buccal swab used FTA<sup>®</sup> (WHATMAN, Maidstone Kent, UK). DNA extraction from urine sediments, hair roots and skin used DNA mini Kit Qiagen (QIAGEN, Courtaboeuf, France) according to the manufacturer's standard protocol.

### Mutation screening

All coding exons and flanking splice sites of *ACVRL1* (GenBank accession number NM\_000020.2) were bidirectionally sequenced as described before (4). Nucleotide numbering reflects cDNA numbering with +1 corresponding to the A of the ATG translation initiation codon in the reference sequence, according to Human Genome Variation Society guidelines ([www.hgvs.org/mutnomen](http://www.hgvs.org/mutnomen)). All coding exons and flanking splice sites of *ENG* (GenBank accession number NM\_004612) were also sequenced.

### Genotyping and linkage analysis

Seven informative microsatellite markers (D12S85, D12S2196, D12S1677, D12S1712, D12S262, D12S1724, and D12S90) were selected for linkage analysis at the locus 12q13.13 (*ACVRL1*). Polymerase chain reaction (PCR) primer sequences and amplification conditions were obtained from the University of California Santa Cruz (UCSC) database. Genotypes were analyzed with GENE-MAPPER 3.5 software.

### Quantitative allele-specific PCR

Experimental conditions for the allele-specific real-time PCR assays were derived from the mismatch amplification mutation assay (Taq-MAMA) (5). Primer pairs specific for the two mutations were designed using PRIMEREXPRESS1.5 such that one primer had the mutation at the 3'-end preceded by a mismatch at position  $n - 1$  (underlined): primer forward c.1390 del: 5'-CCC CCAGGTCCTCTCAGGAT-3''; primer forward c.1388del: 5'-CCCCCAGGTCCTCTCAGCAT-3''; primer reverse: 5'-GGCTTCTCTGGACTGTTGCTAATT-3''.

Specific and quantitative amplification was ensured using serial dilutions of DNA from a control individual in which 75%, 50%, 25%, or 12.5% of the DNA is from the patient bearing the mutation of interest. All real-time PCR experiments were performed using 10 ng of genomic DNA, 0.4  $\mu$ M of each primer and 12.5  $\mu$ l of Sybr Green PCR master mix (Applied Biosystems, Life Technologies SAS, Courtaboeuf, France) in a total volume of 25  $\mu$ l. The RNase P (RNase P control assay from Applied Biosystems) was used as the reference amplicon. Each sample was run in triplicate on an ABI PRISM 7700 Detection system (Applied Biosystems) and three different experiments were used for final quantification. Relative ratios were calculated using the formula  $r = 2^{-\Delta\Delta Ct}$  with  $\Delta\Delta Ct = (Ct_{\text{Mutation}} - Ct_{\text{RNaseP}})_{\text{ind tested}} - (Ct_{\text{Mutation}} - Ct_{\text{RNaseP}})$  (6). The level of mosaicism was assessed on blood DNA. In the case of buccal cells, hair, urine, or skin, there was insufficient DNA from these samples to perform allele-specific assays, but there was no difference between peak height of sequencing scans from blood DNA and other DNA samples.

## Results

### Case

A 40-year-old Caucasian woman (Fig. 1a, II-3), diagnosed with HHT at 38 years, was referred to

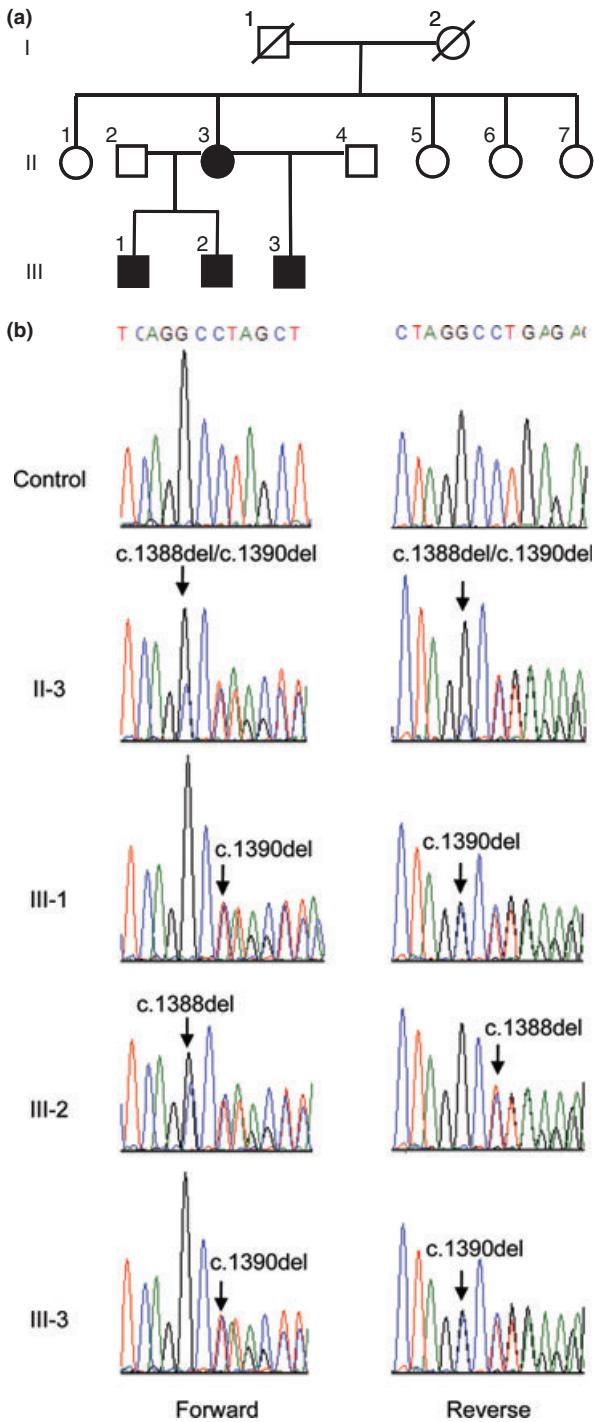

Fig. 1. Molecular analysis of the *ACVRL1* gene. (a) Pedigree of the family. Affected subjects are in black symbols. (b) Detection of *ACVRL1* mutations by direct sequencing of DNA extracted from lymphocytes of the index case (II-1) and her three children (III-1, III-2 and III-3).

the French Reference Centre for Severe Pulmonary Hypertension with a 6-month history of progressive dyspnea. She reported recurrent epistaxes since childhood and she presented with typical telangiectases of the skin, nasal and buccal

cavities. She had multiple liver arteriovenous malformations with a nodular pseudohyperplastic focal aspect and a splenic artery aneurysm. On diagnosis of PAH, the patient was in New York Heart Association (6) functional class III, and the 6-min walk distance was 455 m. Right heart catheterization confirmed severe precapillary pulmonary hypertension with a mean pulmonary artery pressure of 51 mmHg, a pulmonary capillary wedge pressure of 10 mmHg, a right atrial pressure of 4 mmHg and a cardiac index of 6.0 l/min/m<sup>2</sup>. Routine evaluation excluded other conditions associated with precapillary pulmonary hypertension. Thus, specific PAH therapy with (7) oral sildenafil and bosentan was initiated and the patient was alive 69 months after the diagnosis of PAH.

The parents of the patient were deceased. They did not show any signs of HHT or PAH, nor did any of the four sisters of the index case. DNAs were not available for either of the parents or the sisters. The patient has three children from two different fathers. The three children aged 24, 18, and 7 years at examination presented with typical symptoms of HHT with varying degrees according to age. Blood was collected from the patient and her three children for DNA testing. Case II-3 was previously described in a series of *ACVRL1* mutation-associated PAH patients (4) before the children phenotypes and genotypes were available and enabled the elucidation of the molecular findings.

Molecular analysis

Sequencing of the complete coding sequence of the *ACVRL1* gene in the index case initially identified one heterozygous deleterious mutation: c.1388del, p.Gly463AlafsX2 within exon 10 of *ACVRL1*. Targeted genetic testing was performed for her three children. The c.1388del mutation was identified for one child and, surprisingly, a different mutation was identified for the two other children, c.1390del, p.Leu464X (Fig. 1b). We then reanalyzed sequences of the index case and identified the c.1390del mutation on the reverse strand of the DNA sequence (Fig. 1b). The independent transmission of the mutation to the three children showed germinal mosaicism in the mother. Both mutant alleles were detected by direct sequencing in lymphocytes, buccal swab, urine sediments and hair roots of the index patient, indicating a mosaicism affecting ectoderm and mesoderm derivatives. Allelic peak intensities are similar in all tissues tested (data not shown).

To quantify the amount of each mutant allele in the lymphocyte DNA extracted from the index case

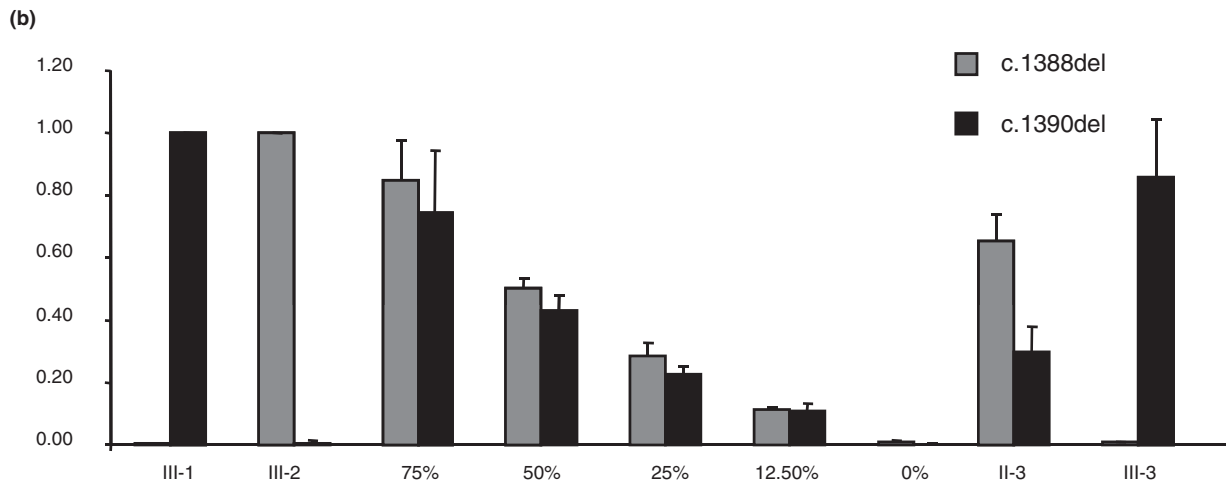
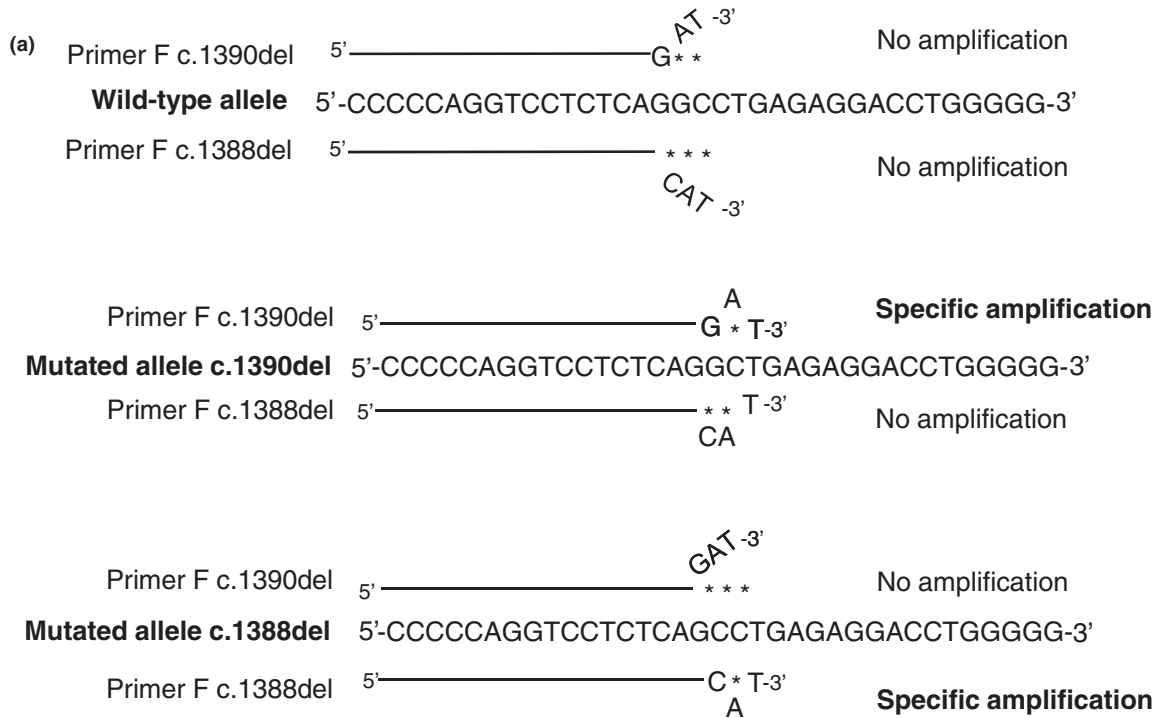

Fig. 2. Allele-specific polymerase chain reaction assay. (a) Primers used for allele-specific amplification introduced a two or three nucleotides mismatch preventing amplification of the wild-type allele and of the mutated allele not specific of the primer used. (b) The y-axis indicates the ratio of the mutated allele in each patient with respect to patient III-1 for the c.1390del mutation and patient III-2 for the c.1388delG mutation who have one copy of the mutated allele. Columns from 75% to 0% show a dilution curve for each allele obtained by mixing DNA from III.3 and III.1 with the wild-type DNA.

(II-3), we developed a real-time PCR procedure, derived from the mismatch amplification mutation assay (TaqMAMA) that specifically amplified the c.1388del or the c.1390del mutations (Fig. 2a). This quantitative analysis revealed that about 60% of lymphocytes of the patient expressed the c.1388del allele and 40% expressed the c.1390del allele (Fig. 2b).

To determine whether the mutants *ACVRL1* alleles c.1388del and c.1390del originated from the same chromosome background, we analyzed

haplotype transmission using seven microsatellite markers surrounding the *ACVRL1* gene. Using the highly polymorphic markers D12S85, D12S2196, D12S1677, D12S1712, D12S262, D12S1724, D12S90 on chromosome 12q13.13, we showed that the three affected children inherited the same maternal haplotype (Fig. 3). This and the independent inheritance of the c.1388del and c.1390del mutations show that the two distinct mutations occurred independently on the same chromosome transmitted by the mother.

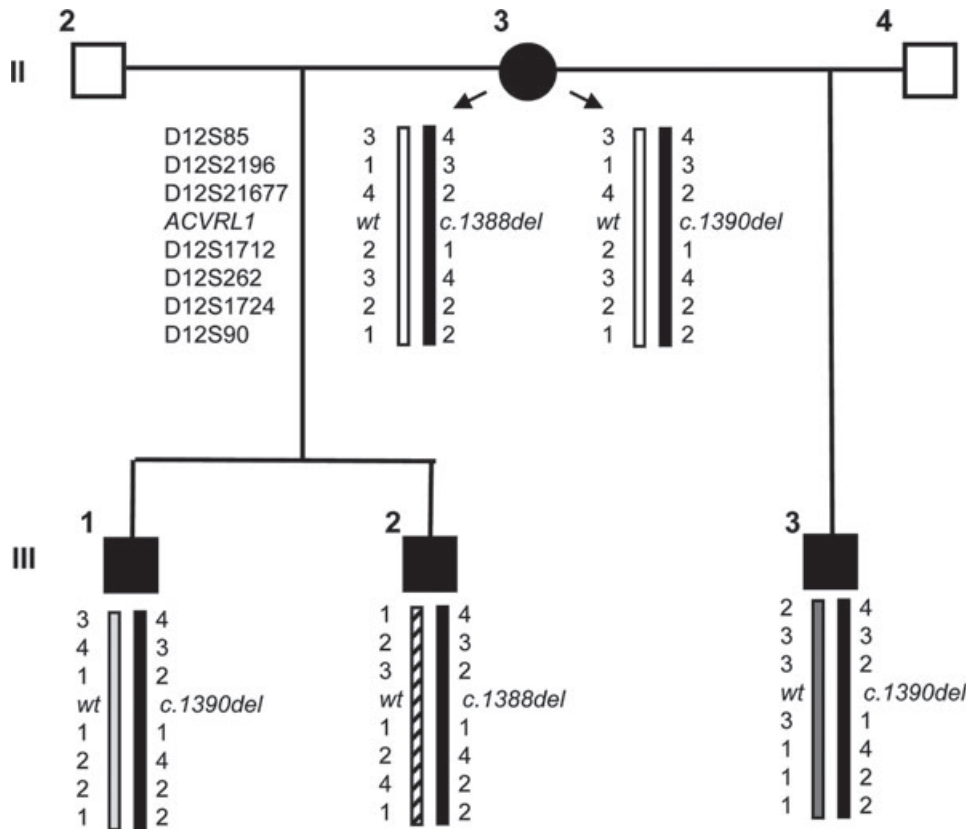

Fig. 3. Haplotype analysis. The inherited haplotypes of the mother spanning the seven microsatellite markers flanking the *ACVRL1* gene are shown together with the two different mutated haplotypes segregating in the offspring.

### Discussion

Here, we report a remarkable case of *ACVRL1* germline mosaicism characterized by the presence of two different mutant alleles derived from the same haplotype and responsible for HHT associated with PAH. The fact that the two mutant alleles segregate independently in the offspring (III-1, III-2, and III-3) is a clear indication of germinal mosaicism in the heterozygous mutant mother (II-3). Furthermore, as there was somatic and germline mosaicism for both mutations in the index parent II-3 on the same chromosome, they likely occurred while she was an embryo *in utero* in I-2 prior to germline segregation (8). Both c.1388del and c.1390del deletions are likely the consequences of a unique mutational event that might have occurred at an early stage of embryogenesis of II-3; such mutations occurring prior to germline segregation can lead to genetic mosaicism in both somatic and germline tissues (8). Mutation events that occur following germline segregation would result in germinal mosaicism but not somatic mosaicism (9). Indeed, the index case (II-3) carries three different haplotypes in her germline and somatic cells, among

them two carry different mutations which emerged from the same haplotype and which were independently transmitted to the offspring. However, the unique precursor genetic event was no longer detectable.

The DNA sequence surrounding both *ACVRL1* deletions includes many motifs that are frequently associated with microdeletions/microinsertions, including topoisomerase cleavage sites, repeats, immunoglobulin mutation motifs, the fragile X-deletion hotspot motif and DNA structure-forming motifs (Fig. 4) (10–12). This is a strikingly high number of these mutation motifs for a given locus. Also present are several polypurine/polyprimidine tracts and palindromic (inverted repeat) sequences that are capable of forming triple-stranded DNA structures and hairpin/cruciform structures – both of which have been associated with mutations (10–12). Interestingly, both the c.1388del and the c.1390del mutations are located within the stem region of the putative cruciform/hairpin structure. Upon deletion of either the G or the C, the ability for this cruciform/hairpin would be lost (Fig. 4). We can speculate a template switching model that can arise by paused replication fork or arrested DNA repair synthesis, induced

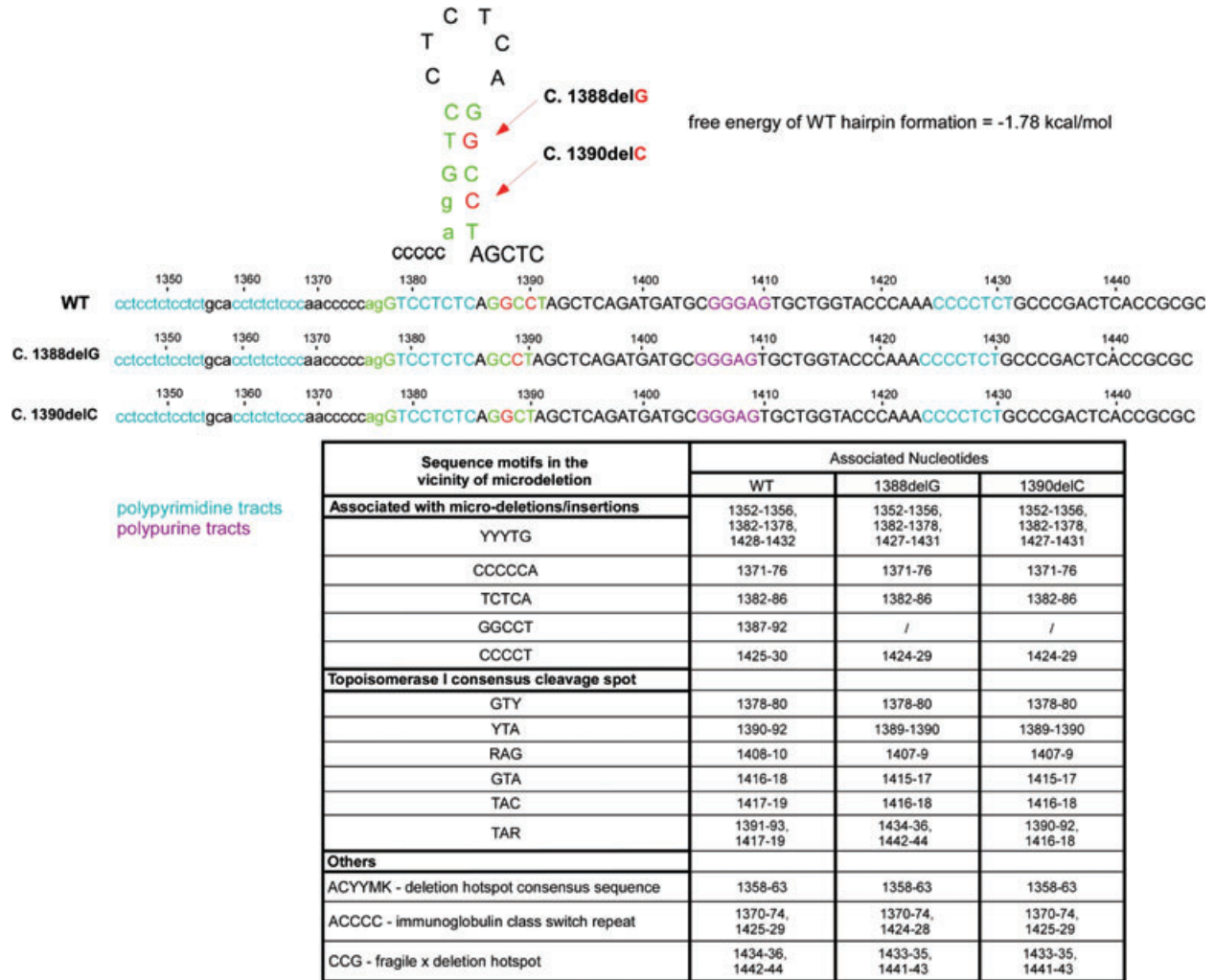

Fig. 4. Mutation analysis. Sequence motifs previously associated with microinsertions and microdeletions (10) and their association with the deletion mutations in the *ACVRL1* gene. The hairpin formation in the wild-type allele has a free energy of  $-1.78$  kcal/mol. The same hairpin structure was not able to form in either of the mutant allele *in silico* using MFOLD (<http://mfold.rna.albany.edu/>).

by secondary structures, followed by restarted synthesis mediated by a strand/template switching process which can provoke the loss of bases. The high number of mutation motifs associated with this region of the *ACVRL1* coupled with the fact that this individual has incurred a complex genetic event at this site suggests that this may well be a mutation hotspot, and several *ACVRL1* mutations have been described in this area of the gene, including microdeletion/microinsertions (13, 14). PAH is a rare complication of *ACVRL1* mutation carriers (2–4). *ACVRL1* mutation carriers were shown to have a younger age at PAH diagnosis and a worse prognosis when compared with PAH patients carrying a *BMP2* mutation, the major predisposing gene to PAH, or patients without mutation identified (4). PAH is in particular observed in early childhood in *ACVRL1* mutation carriers and the poor prognosis of these HHT

and PAH-associated *ACVRL1* mutations precludes their transmission. Inversely, mosaicism can attenuate HHT and PAH phenotypes in subjects carrying a *de novo* mutation in the *ACVRL1* gene (15, 16). However, in the case reported here, occurrence of the mutation during early embryogenesis conferred a complete phenotype with symptoms starting in childhood.

The case of germinal mosaicism described here illustrates the complexity of transmission of the mutation in progeny and might explain pseudo-revertant cases of mutation transmission, which indeed can be due to germinal mosaicism.

#### Acknowledgements

We are grateful to the patients and staffs who participated in this study. This work was supported by DGOS support for rare disease diagnosis and Assistance Publique-Hôpitaux de Paris. M. M. A. is supported by a Doctoral Training Award from the Canadian

Institutes of Health Research (CIHR) Collaborative Graduate Training Program in Molecular Medicine and an Ontario Graduate Scholarship. Work in the Pearson lab is supported by the CIHR.

## References

1. Shovlin CL. Hereditary haemorrhagic telangiectasia: pathophysiology, diagnosis and treatment. *Blood Rev* 2010; 24: 203–219.
2. Tuder RM. Pathology of pulmonary arterial hypertension. *Semin Respir Crit Care Med* 2009; 30: 376–385.
3. Trembath RC, Thomson JR, Machado RD et al. Clinical and molecular genetic features of pulmonary hypertension in patients with hereditary hemorrhagic telangiectasia. *N Engl J Med* 2001; 345: 325–334.
4. Girerd B, Montani D, Coulet F et al. Clinical outcomes of pulmonary arterial hypertension in patients carrying an ACVRL1 (ALK1) mutation. *Am J Respir Crit Care Med* 2010; 181: 851–861.
5. Glaab WE, Skopek TR. A novel assay for allelic discrimination that combines the fluorogenic 5' nuclease polymerase chain reaction (TaqMan) and mismatch amplification mutation assay. *Mutat Res* 1999; 430: 1–12.
6. Livak KJ, Schmittgen TD. Analysis of relative gene expression data using real-time quantitative PCR and the 2(-Delta Delta C(T)) Method. *Methods* 2001; 25: 402–408.
7. The Criteria Committee of the New York Heart Association Nomenclature and criteria for diagnosis of diseases of the heart and blood vessels. Boston: Little Brown, 1964.
8. Pearson CE. Slipping while sleeping? Trinucleotide repeat expansions in germ cells. *Trends Mol Med* 2003; 9: 490–495.
9. Tome S, Panigrahi GB, Castel AL et al. Maternal germline-specific effect of DNA ligase I on CTG/CAG instability. *Hum Mol Genet* 2011; 20: 2131–2143.
10. Ball EV, Stenson PD, Abeyasinghe SS et al. Microdeletions and microinsertions causing human genetic disease: common mechanisms of mutagenesis and the role of local DNA sequence complexity. *Hum Mutat* 2005; 26: 205–213.
11. Christodoulou J, Craig HJ, Walker DC et al. Deletion hotspot in the argininosuccinate lyase gene: association with topoisomerase II and DNA polymerase alpha sites. *Hum Mutat* 2006; 27: 1065–1071.
12. Nichol Edamura K, Pearson CE. DNA methylation and replication: implications for the “deletion hotspot” region of FMR1. *Hum Genet* 2005; 118: 301–304.
13. Lesca G, Plauchu H, Coulet F et al. Molecular screening of ALK1/ACVRL1 and ENG genes in hereditary hemorrhagic telangiectasia in France. *Hum Mutat* 2004; 23: 289–299.
14. Prigoda NL, Savas S, Abdalla SA et al. Hereditary haemorrhagic telangiectasia: mutation detection, test sensitivity and novel mutations. *J Med Genet* 2006; 43: 722–728.
15. Wooderchak W, Gedge F, McDonald M et al. Hereditary hemorrhagic telangiectasia: two distinct ENG deletions in one family. *Clin Genet* 2010; 78: 484–489.
16. Best DH, Vaughn C, McDonald J et al. Mosaic ACVRL1 and ENG mutations in hereditary haemorrhagic telangiectasia patients. *J Med Genet* 2011; 48: 358–360.